

The Campus Network of the University of Tokyo

Akira Kato



The Univ of Tokyo ITC/WIDE Project
kato@wide.ad.jp

Agenda

- ☆ Introduction of Unif. of Tokyo
- ☆ Campus network of the Univ. of Tokyo
 - Initial UTnet
 - UTnet-2
 - UTnet-3
- ☆ Current operation of UTnet

Univ. of Tokyo

☆ One of the biggest universities in Japan

- Established in 1878
- 4,000 educational staffs
- 3,500 staffs including medical/technical staffs
- 15,000 undergraduates
- 6,000 MS course students
- 6,000 PhD course students

☆ One of the most complex universities in Japan

- 10 Faculties
- 15 Graduate Schools
- 11 Research Institutes
- 22 Centers
- Each division prefers autonomous administration

U-Tokyo Campuses

☆ Major campuses in/around Tokyo

- Hongo (the biggest, the HQ is located)
- Komaba-1 for Liberal Arts
- Komaba-2, Kashiwa, Shirogane, Nakano for research

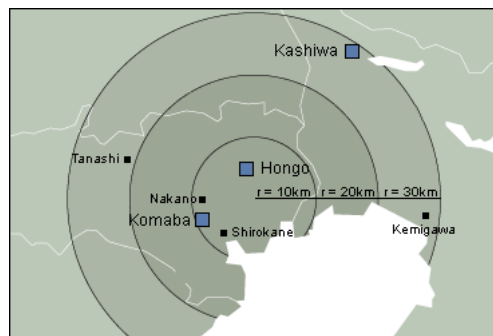

U-Tokyo Campuses

- ☆ **More than 40 Remote Research Facilities**
 - Scattered over the country

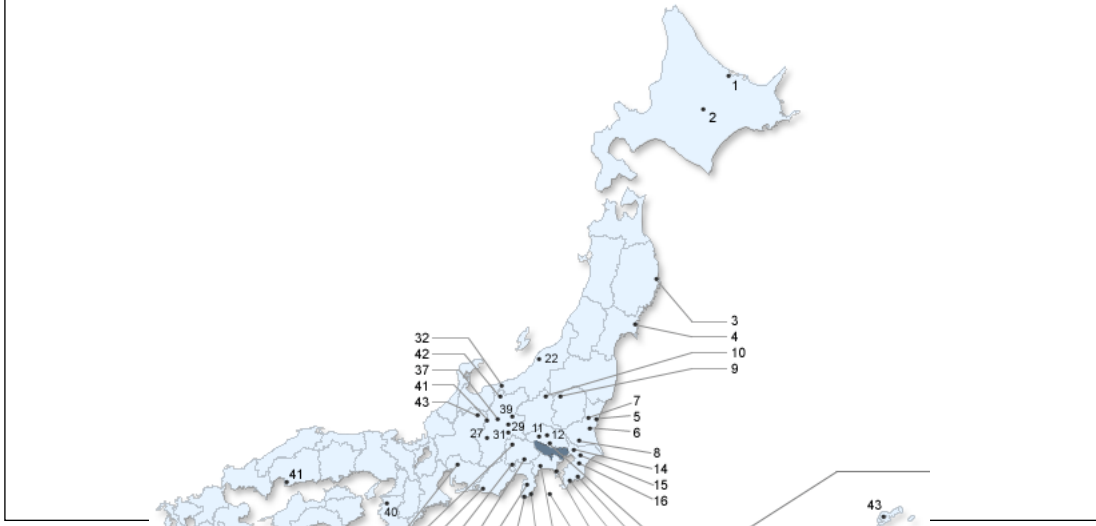

UTnet

- ☆ **The first campus network of the Univ. of Tokyo**
 - F. of Engineering hold its network
 - It was replaced with UTnet
- ☆ **Installation was done in 1990--1993**
 - The backbone consisted with 3 FDDI rings
 - Regular routed IP
 - Bridged for F. of Sci for DECNET
 - Bridged for Office use for IPX
 - Fujitsu LLU-E's were used
 - 400Mbps Fujitsu proprietary ring for multimedia
 - Not widely used, unfortunately
 - Fibier installed exactly along as topology
 - 6MMF + 2SMF
 - 10Base-5 Ethernet was the common access method
 - 64kbps--1.5Mbps inter-campus link
 - Leased lines

UTnet

- ☆ **Since 1995, the network sometimes got unstable**
 - Due to FDDI optical failure
 - Performance issue

UTnet-2

- ☆ **Brand-new infrastructure replaced UTnet in 1996**
 - New infrastructure is referred to as UTnet-2
 - Extensive installation of fiber optics
 - 24 MMF + 8 SMF for most buildings
 - 5 hubs in Hongo, 2 hubs in Komaba-1
 - Single hub for other campuses
 - Structured FDDI rings
 - 5 FDDI with a backbone FDDI in Hongo
 - Cisco7505/7507's for inter-rings
 - About 100 Cisco4500's for most buildings

UTnet-2

☆ **ATM infrastructure introduced along with FDDI**

- Inter-campus connectivity
 - 3--60Mbps ATM PVC's from a carrier
- ATM LAN-Emulation was introduced
- Access to JGN
 - Japan Gigabit Network : 1999--2004

☆ **ATM was not deployed widely**

- ATM NIC was not so getting cheaper
- ATM switches were expensive
- 155Mbps ATM required access through fibers
- Problematic in interoperability in SVC
 - IPoA, LANE
- ATM is no longer used

UTnet-2

☆ **Only connectivity was provided**

- Storage/Contents were up to users
- DNS was an exception

☆ **UTnet provided inter-building connectivity only**

- Each department was responsible intra-building network
 - Inter-floors
 - Wiring closet to each room
- **Because UTnet doesn't have**
 - Enough budget to cover the cost
 - Enough human resources for maintenance
 - Each division wants to do it by itself
- This may need to be re-studied for total efficiency

UTnet-2 Configuration

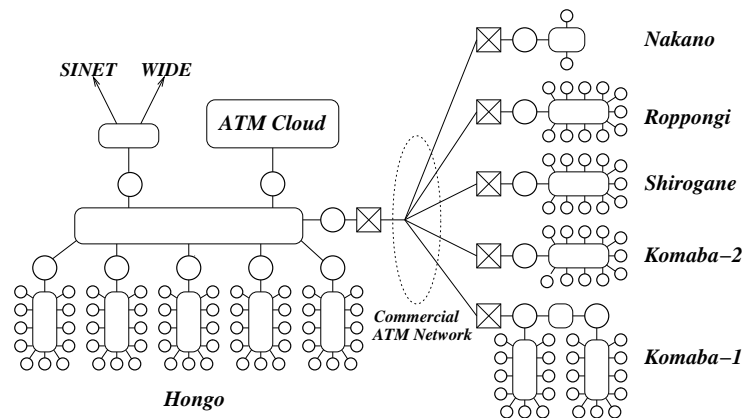

UTnet-3

- ☆ **Upgraded into UTnet-3 in 2002**
- ☆ **Fibers installed in UTnet-2 are used**
 - Some additional fibers installed
 - Large requirements for single mode fibers
 - 1000Base-SX is not sufficient for most cases
- ☆ **Gears have been newly introduced**
 - 15 Catalyst650x/SVM2 introduced
 - 2 GbE backbone, star-shaped
 - Cat650x runs CatOS + IOS
 - No integrated IOS was available at installation
 - Integrated IOS has some restrictions (# of SPAN)
 - ~200 Catalyst2924M/3524XL's for building access
 - Most buildings have FE access
 - Some buildings have GbE access
 - FE access gradually upgraded to GbE
- ☆ **Now we have ~600 subnets/vlans**

Layer-3 switches

☆ Essentially they are routers, but

- Many ports/interfaces
- Per port cost is far less than routers
- Provides layer-2 functionality as well
- VLAN's are supported
- Allow very flexible configuration
- Almost full routing protocol implementations

☆ Some drawbacks

- Buffer space per port may be limited
- May fall slower path when # of flows exceeds a limit

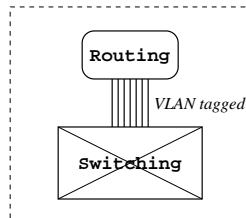

UTnet-3 Configuration

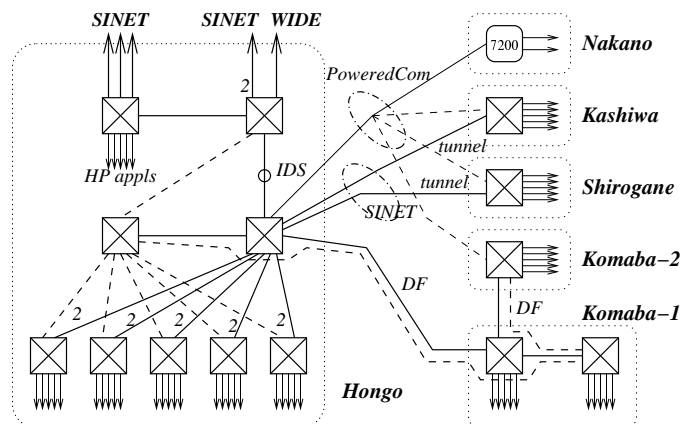

Inter-Campus links in UTnet-3

- ☆ **DF access to Komaba-1, then Komaba-2**
 - 4-GbE using CDWM by Hitachi Cable
 - UTnet, ECCS, Research, and backup
- ☆ **SuperSINET access in Kashiwa and Shirogane**
 - Each with GbE
 - Tunneled to avoid RIP-2 overhead
 - SINET allows 1500+GRE MTU
 - 10Mbps Carrier's Ethernet service for backup
- ☆ **Nakano campus has a 100Mbps Ethernet access**
- ☆ **Remote Research Facility**
 - 64kbps leased lines and Frame Relay's were used
 - In migration to "IP tunnel over NAT equipped xDSL"
 - "ip tcp adjust-mss", "set ip df 0" are useful

UTnet-3 Operation

- ☆ **UTnet provides routed IPv4 connectivity primary**
- ☆ **There is a fee for IPv4 address and connectivity**
 - \$250/yr for a /24
 - \$250/yr for 100Mbps, \$1000/yr for GbE
 - Used for maintenance/enhancement
- ☆ **Extended VLANs connect buildings at layer-2**
 - Easily be implemented with layer-3 switches
 - Some labs span multiple locations
 - Firewall protected subnets can serve multiple buildings
 - Office systems require separate subnets
 - For security isolation/firewall
 - Unique VLAN ID is assigned
 - to avoid confusion
 - Old catalyst switches supports 1-1022

UTnet-3 Operation

- ☆ **Dedicated fiber access offered if resource available**
 - Only inside a campus
 - Subject for extra fee
 - Suitable for bulk data transfer
 - Sometimes with SuperSINET
- ☆ **No multicasting service is provided**
 - May be necessary to broadcast educational contents

IPv6 in UTnet-3

- ☆ **IPv6 is not widely installed**
 - A Cisco7505 routes everything
 - IPv6-enabled subnets extended to it by tagged vlan
 - About 10 customer subnets are IPv6 ready
- ☆ **It is important to provide IPv6 environment**
 - Especially for students in computer science department
 - It is necessary to learn IPv6 programming

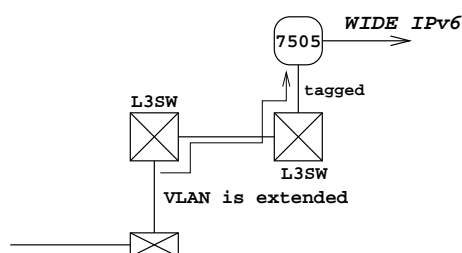

UTnet-3 Operation

☆ Upgrading in progress

- Replace Cat2924E/3524XL : 3-4 year project
 - Cat2950/2970 for most cases
 - Cat3670 for some buildings
- Upgrading to SUP720
 - Wire-rate IPv6 routing
 - Potential for support of 10GE
 - Only one or two upgrade possible in each year
- Introduction of 10GE
 - for JGN2 and WIDE initially
 - for SINET when ready

UTnet Staff

☆ ITC has five divisions

- Super-Computing
- Campus-networking
- Media (including Educational computing system)
- Digital Library
- Management

☆ Campus-networking division

- 1 professor, 3 assoc professors, 3 research associates
 - They are suggesting the operation
 - They works with technical staff in some cases
- 7 technical staffs
 - Skill varies by person

UTnet in Finance

- ☆ **Very rough picture**
- ☆ **Annual budget is about \$1M**
 - ~60% for inter-campus access
 - ~20% for equipment maintainance
 - ~20% for upgrading equipment
 - Salary is extra
- ☆ **Income**
 - 70% from the University
 - 30% from the divisions
 - Based on their usage
 - Encourage conservation

UTnet-3 Security

- ☆ **Users have large diversity**
 - Email/web through those who requires GbE or more
- ☆ **Management of each host is up to its user**
 - UTnet is impossible to manage 40k+ hosts
 - Large diversity of OS and releases
 - 25k hosts accessible directly to UTnet
- ☆ **Strong security enforcement is hard to implement**
 - No clear policy is defined
 - No clear authority has been defined
- ☆ **What's are doing right now**
 - Encourage use of virus protection software
 - External traffic is IDS monitored
 - Email virus cleanup enforced on emergency cases

UT-CERT

☆ **UT-CERT : Campus-wide CERT**

- Interaction with divisional CERT
 - Asks "actual" response to an incident
- No full-time staff available
 - Part-time academic employees w/ knowledge

☆ **Tightly collaborate with UTnet**

- Actual first-aid is done by UTnet
 - Applying ACLs to particular IP address
 - Deconfigure the ACL upon request
- Sometimes incidents reported by the IDS
- Security database is being operational
 - Keep track of each incident
 - When/How/by Who it is responded

What's missing

☆ **Extensive User Support**

- Technical staff works 9am-5pm Mon-Fri
- Shift work introduced
 - some folks works 12pm-8pm Mon-Fri
- No support offered in the weekends

☆ **Active consultation**

- Need deep knowledge of relevant technologies
 - Network behavior
 - Operating Systems
 - Applications

☆ **Advanced troubleshooting**

- Measurement of user's network performance
 - Identify the reasons of the trouble
 - Then fix them

Summary of the UTnet

- ☆ **UTnet has about 15 years history**
 - Various up-to-date technologies are introduced
- ☆ **Providing stable IP reachability**
 - IPv6 support is being introduced
 - About 10 subnets at this moment
- ☆ **We need to improve the environment**
 - Accomodating high-performance applications
- ☆ **What's to do**
 - Extensive support of "each" user
 - Prompt response to security incidents