

Noise Figure, Noise Factor and Sensitivity

Wireless Systems Instructional
Design

1

Noise

- “Any unwanted input”
- Limits systems ability to process weak signals
- Sources:
 1. Random noise in resistors and transistors
 2. Mixer noise
 3. Undesired cross-coupling noise
 4. Power supply noise
- Dynamic range – capability of detecting weak signals in presence of large-amplitude signals

2

Noise (contd.)

- “noisiness” of the signal measure = signal-to-noise ratio (frequency dependant)

$$SNR = \frac{S(f)}{N(f)} = \frac{\text{average - signal - power}}{\text{average - noise - power}}$$

- Random noise

- External
 - Atmospheric
 - Interstellar
- Receiver internal
 - Thermal
 - Flicker noise (low frequency)
 - Shot noise

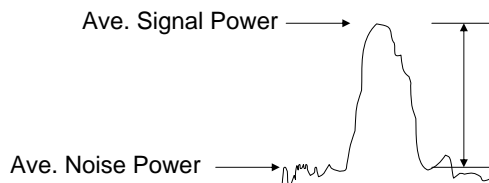

3

“Sky” Noise

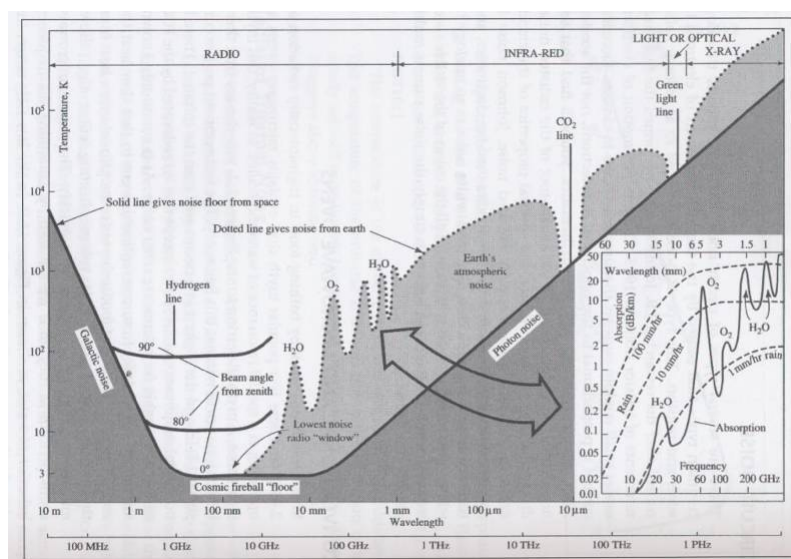

4

Noise factor

- **IEEE Standards:** “The noise factor, at a specified input frequency, is defined as the ratio of (1) the total noise power per unit bandwidth available at the output port when noise temperature of the input termination is standard (290 K) to (2) that portion of (1) engendered at the input frequency by the input termination.”

$$F = \frac{\text{Noise_Power_at_inputport}}{\text{Noise_Power_at_outputport}}$$

5

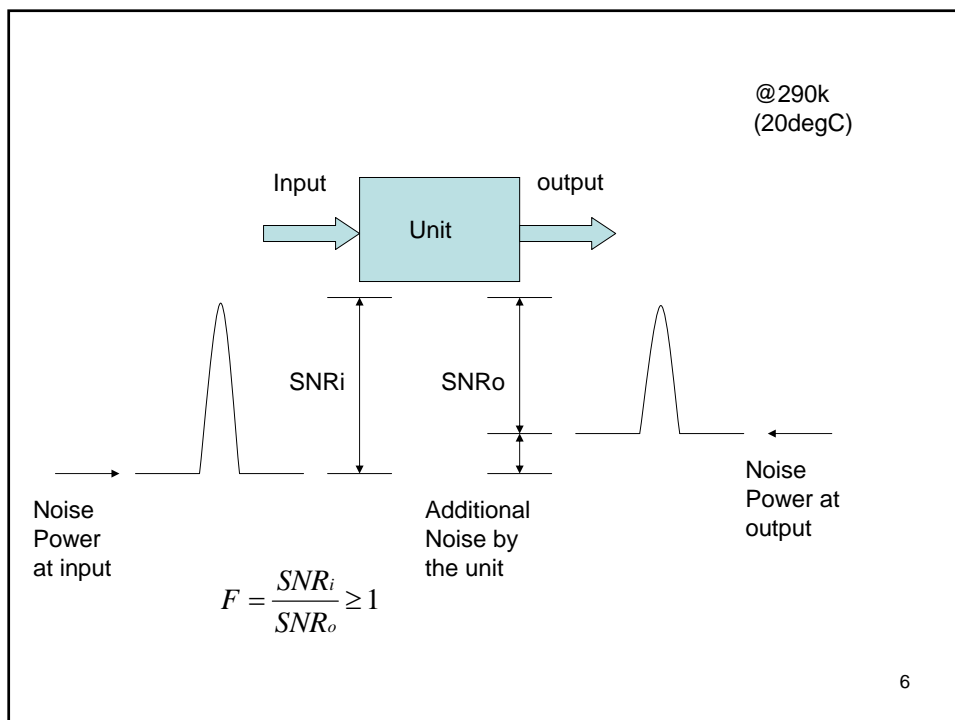

Noise factor (cont.)

$$F = \frac{S_i/N_i}{S_o/N_o} = \frac{N_o \times S_i}{N_i \times S_o} = \frac{(N_i G(f) + N_a) S_i}{N_i S_o} = 1 + \frac{N_a}{G(f) N_i}$$

$$\because S_o = G(f) S_i, N_o = N_i G(f) + N_a$$

- G(f): Gain at f[Hz], Na: Unit Noise
- It is a measure of the degradation of SNR due to the noise added - $F = \frac{SNR_i}{SNR_o} \geq 1$
- Implies that SNR gets worse as we process the signal $F = 1 + \frac{N_a}{kT}, G(f) = kT$
- K is Boltzman constant $1.38 \times 10^{-23} [W / Hz / K]$ 7

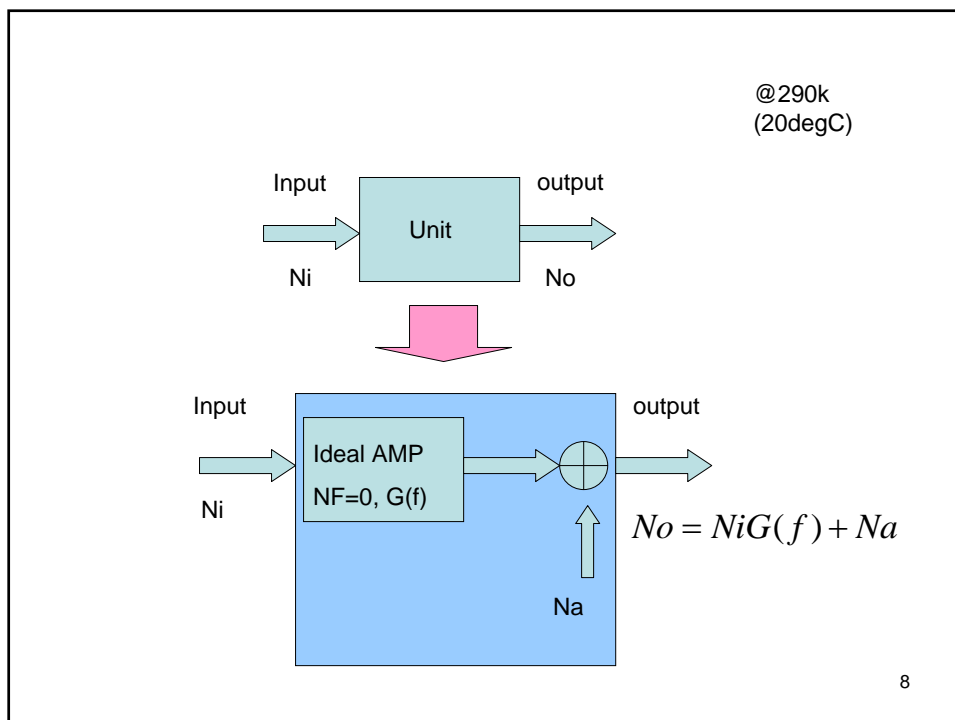

Noise factor (cont.)

- Quantitative measure of receiver performance wrt noise for a given bandwidth
- Noise figure $NF = 10\log(F)$
 - Typically 8-10 db for modern receivers
- Multistage (cascaded) system

$$F = F_1 + \frac{F_2 - 1}{G_1} + \frac{F_3 - 1}{G_1 G_2} + \dots + \frac{F_n - 1}{G_1 G_2 \dots G_{n-1}}$$

9

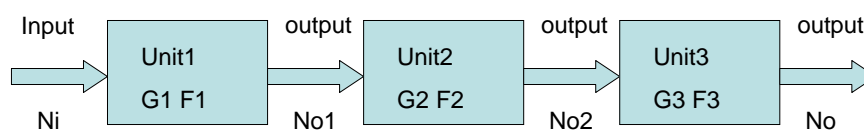

$$F = F_1 + \frac{F_2 - 1}{G_1} + \frac{F_3 - 1}{G_1 G_2}$$

$$F = F_1 + \frac{F_2 - 1}{G_1} + \frac{F_3 - 1}{G_1 G_2} + \dots + \frac{F_n - 1}{G_1 G_2 \dots G_{n-1}}$$

10

NF example

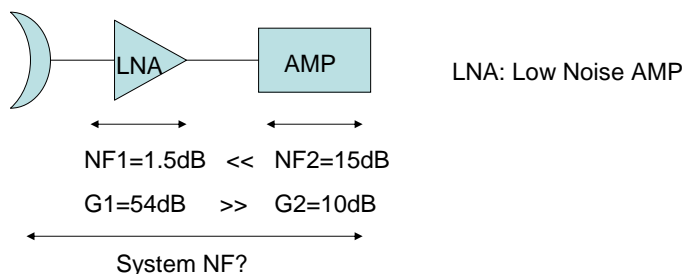

$$F = F_1 + \frac{F_2 - 1}{G_1}$$

$$F = 10^{\frac{1.5}{10}} + \frac{10^{\frac{15}{10}} - 1}{10^{\frac{54}{10}}}$$

$$F = 1.412$$

$$NF_{total} = 1.498[\text{dB}] \approx NF_1$$

11

Sensitivity

- Minimum detectable input signal level for a given output SNR (also called *noise floor*)
- Not necessarily related to required output SNR

12

Link Budget

- “Quick” way of estimating RF link performance
 - Why quick?
 - The formula only take account thermal noise

$$P_{rx} = \underbrace{P_{tx} + G_{tx}}_{EIRP} + G_{rx} - L - A_{misc}$$

- P_{rx}, P_{tx} – received and transmitted power (dB)
- G_{rx}, G_{tx} – antenna gain (dBi)
- L – path loss
- A_{misc} – miscellaneous attenuation

13

Path Loss

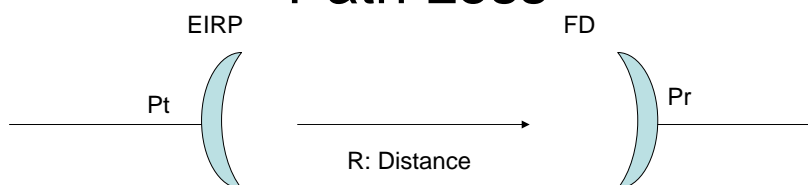

$$FD = \frac{EIRP}{4\pi R^2} : \text{Flux Density}$$

$$A_r = \frac{G_r \lambda^2}{4\pi} : \text{Effective Area of Antenna}$$

$$Pr = FD \times A_r = \frac{EIRP}{4\pi R^2} \times \frac{G_r \lambda^2}{4\pi}$$

$$[Pr] = EIRP - [4\pi R^2] + G_r + \left[\frac{G_r \lambda^2}{4\pi} \right]$$

$$= EIRP + G_r - \underbrace{10 \log \left(\frac{4\pi R^2}{\lambda^2} \right)}_{\text{Path Loss}} [dB]$$

14

Link Budget (WiFi)

- Path loss (Friis formula):

$$L(\text{dB}) = 92.45 + 20\log(F) + 20\log(d)$$

- $L = 40 \text{ dB} + 20\log(d)$ @ 2.4 GHz

- $L = 48 \text{ dB} + 20\log(d)$ @ 5.7 GHz

- Transmit power:

- $15 - 20 \text{ dBm}$ (30 – 100 mW)

- Antenna gain: given in decibels over an isotropic antenna (dBi)

- 0dBi (isotropic), 8 dBi (biquad), 15 dBi (helix), 24 dBi (parabolic)

15

Link Budget (cont.)

- Received power (sensitivity)

	Orinocco	Aironet 350	SNR
11Mbps	-82 dBm	-85 dBm	16 dB
5.5 Mbps	-87 dBm	-89 dBm	11 dB
2 Mbps	-91 dBm	-91 dBm	7 dB
1 Mbps	-94 dBm	-94 dBm	4 dB

16

Link Budget (cont.)

- Amisc:
 - Cables (@ 2.4 GHz)
 - RG 174: 2 [dB/m]
 - RG 58: 1 [dB/m]
 - RG 213: 0.6 [dB/m]
 - IEEE 802.3: 0.3 [dB/m]
 - LMR-400: 0.22 [dB/m]
 - Connectors (BNC, N, SMA)
 - 0.1 – 1 dB loss

17

Link Budget (Sat Com Ex.)

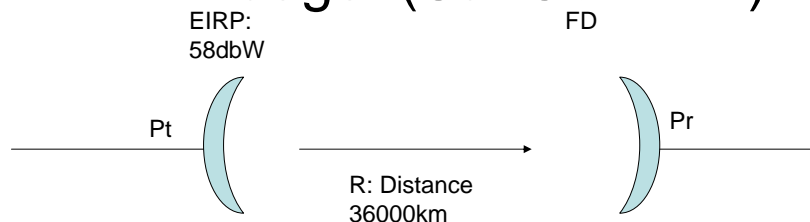

$$FD = \frac{EIRP}{4\pi R^2} \text{ : Flux Density}$$

$$Ar = \frac{G_r \lambda^2}{4\pi} \text{ : Effective Area of Antenna}$$

$$Pr = FD \times Ar = \frac{EIRP}{4\pi R^2} \times \frac{G_r \lambda^2}{4\pi}$$

$$[Pr] = EIRP - [4\pi R^2] + G_r + \left[\frac{G_r \lambda^2}{4\pi}\right]$$

$$= EIRP + G_r - 10 \log\left(\frac{4\pi R^2}{\lambda^2}\right) [dB]$$

$$FD = \frac{EIRP}{4\pi R^2}$$

$$FD = 58 - 162.5 = -104.5 [dBW/m^2]$$

$$G_r = 46 dB @ 1.8m\phi, 42 dB @ 1.2m\phi$$

$$[Pr] = EIRP + G_r - 10 \log\left(\frac{4\pi R^2}{\lambda^2}\right) [dB]$$

$$= 58 + 46 - 206 = -109 [dBW] : 1.8m\phi$$

$$= 58 + 42 - 206 = -113 [dBW] : 1.2m\phi$$

18

Carrier to Noise

$N = kT_{sys}B$
 T_{sys} : System Noise Temperature[k]
 B : Signal Bandwidth[Hz]
 k : Boltzmann Constant

$C/N = P_r / kT_{sys}B$
 $= EIRP \times G_r \times \left(\frac{\lambda}{4\pi R^2}\right)^2 / (kT_{sys}B)$
 $[C/N] = EIRP + G/T - \left(\frac{\lambda}{4\pi R^2}\right)^2 - kB[dB]$ where $G/T = G_r/T_{sys}$

19

Carrier to Noise Example

Ant 1.8m
 NF=1.5dB
 EIRP=58dBW

$B: 27\text{MHz}$

$C/N = EIRP + G/T - \left(\frac{4\pi R^2}{\lambda^2}\right) - kB$
 $= EIRP - L_{sp} + G/T - k - B$
 $R: 36000\text{km}, \lambda: 2.4\text{cm @ } 12\text{GHz}, k: 228.6$
 $G/T = G_r - T_{sys} = 24[dB]$
 Where $T_{sys} = T_0(NF - 1)$ and $T_0 = 290K$
 $C/N = 58 - 206 + 24 + 228.6 - 74.31$
 $= 30.29[dB]$

If required $C/N = 12\text{dB}$,
 $C/N_{\text{Margin}} = 30.29 - 12 \cong 27\text{dB}$

20

Noise

- Again, what is Noise?
 - Undesired signal that come into the system
 - Thermal Noise
 - IM: Inter-moderation products
 - Interference from the other system
 - Same channel
 - » Different location system that use same channel
 - » The other polarization system that use same channel
 - Neighboring channel system
 - The object that radiate power in the same band
 - » Microwave oven interference
- All the undesired power that come into the band become the noise

$$C/N_{total} = C/N \oplus \sum C/I_{interference}$$

21

Case Study

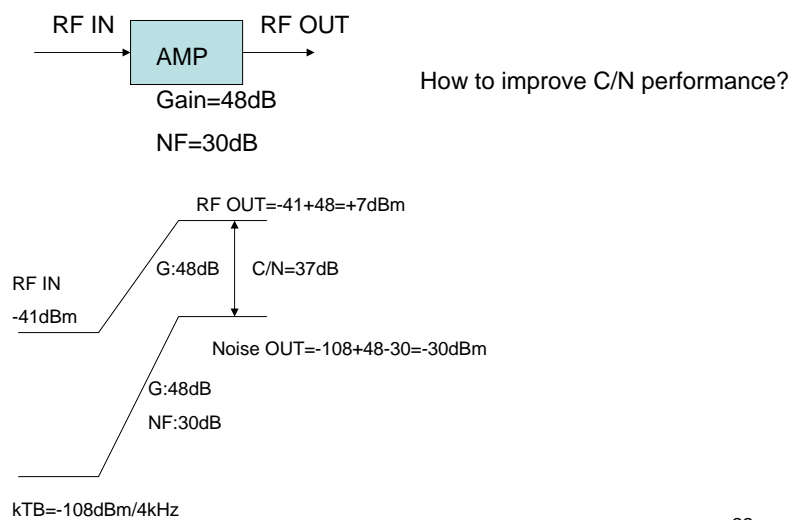

22

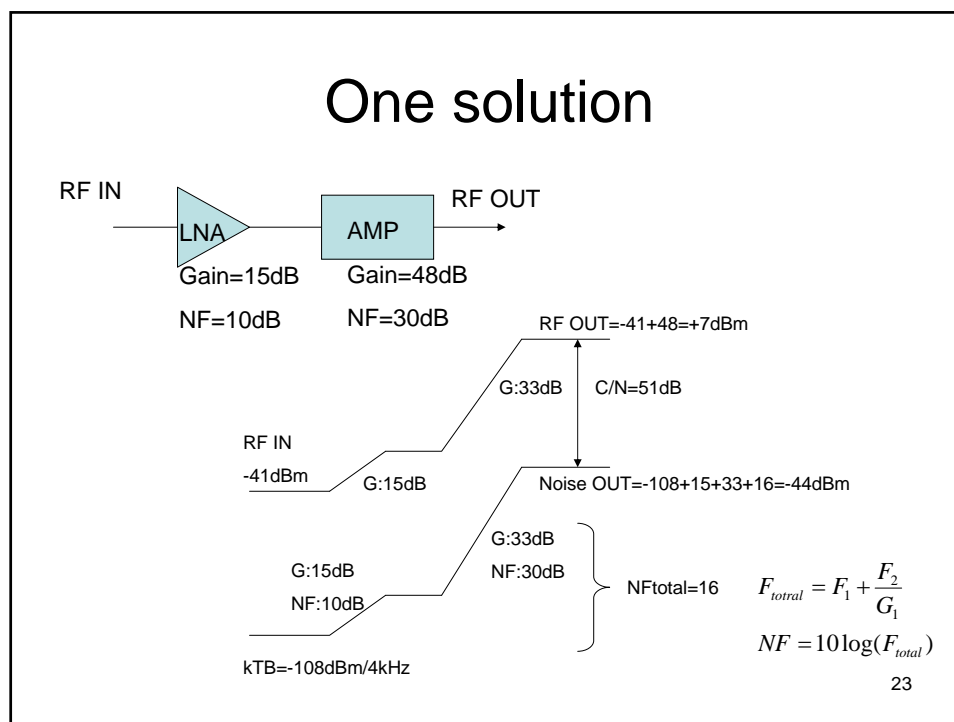

Reference

- Recommended document
 - Noise and Measurement
 - Agilent technology technical note
 - Fundamentals of RF and Microwave Noise Figure Measurement
- http://www.home.agilent.com/agilent/redirector.jsp?action=obs&nid=-11143.0.00&lc=eng&cc=US&ckey=1000034254%3Aeapsg%3Adow&pubno=5980-0164E<ype=&ctype=AGILENT_EDITORIAL